

IsoMax Clip System - Wall or Ceiling

Load Specification for IsoMax Clip System

The IsoMax Clip is designed to carry a drywall furring channel with one or more layers of gypsum wallboard attached.

The maximum design load capacity for the IsoMax Clip in shear (wall application) or in tension (ceiling application) is as follows. Design load calculations are based on tested loading to failure where the furring channel deforms and pulls out.

Design Load Maximum for Wall or Ceiling Application

22kgs per IsoMax Clip

Installation of IsoMax Clip System - Walls and Ceilings

- Spacing of IsoMax Clips on the furring channel shall be a maximum of 1200mm
- Spacing between furring channels shall be a maximum of 600mm
- Use only the CMS furring channel per the Furring Channel Requirements section and Load Specification section of this document
- (Walls only) The first layer of gypsum wallboard shall align seams between sheets on the centerline of the horizontal furring channels
- (Walls only) The bottom row of IsoMax Clips with furring channel(s) should be a maximum 76mm to the center of the channel from the floor. The top row should be within 150mm of the ceiling
- (Walls only) The first row of gypsum wallboard sheets at the bottom of the wall shall be installed with the long dimension supported on 6mm thick continuous resilient isolation strip, CMS 3912 Isolation Strip
- (Ceilings only) The IsoMax Clips should be within 150mm of the ceiling perimeter at the end of the furring channel run
- (Ceilings only) The first row of channel at the ceiling perimeter should be a maximum 150mm from the wall
- Furring channels are installed perpendicular to the framing members

General Information

All potential sound leaks; gaps around outlets, window, or door frames; pipe penetrations and the like should be sealed with a non-hardening acoustical sealant such as CMS dB sealant.

The IsoMax Clip system is available in the UK and Ireland exclusively from CMS Acoustics as the result of a joint venture between UK based CMS Acoustics and Kinetics™ Noise Control, one of the world leaders in noise control.

For information on other Kinetics™ architectural and anti-vibration products available from CMS Acoustics, please contact us on **01925 577711**.

Step 1

Attach IsoMax Clips per CMS Acoustics layout guidelines for walls or ceilings. See attached layout drawings.

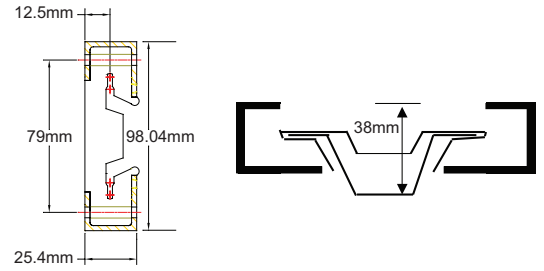

Step 2

To affix the IsoMax Clips to the sub-wall/partition
Secure IsoMax Clips with a single fastener on one end only
Into timber use No. 8 dia screws x 65mm long
Into steel use either No. 8, 10 or 12 self tapping screws 40mm long
Into concrete or masonry use 4mm dia x 60mm long screws into matching Rawlplug/Fischer fixing system

Optional

Alternate method for Step 2. Snap IsoMax Clips onto furring channel.
Hand slide IsoMax Clips to proper location on the furring channel.
Fasten both ends of the IsoMax Clip to secure the channel.

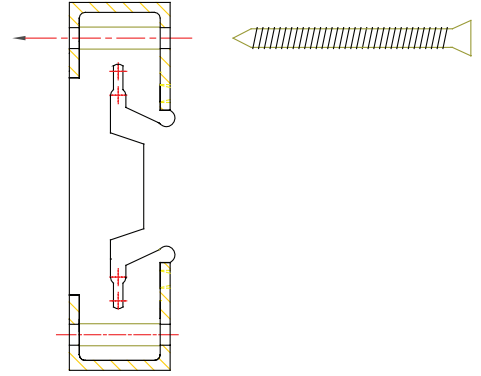

Step 3

Grip unsecured rubber end, snap in channel. Secure with second screw/anchor.

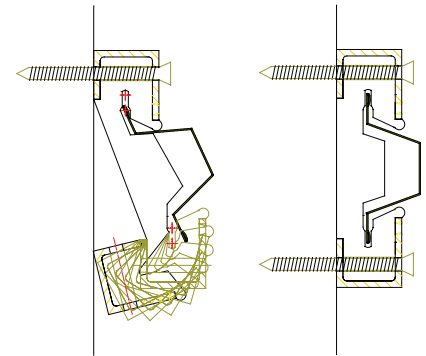

Furring Channel Requirements

Minimum 0.7mm ga with hemmed edge

Standard – 23mm deep channel

Splice furring channel with a 150mm overlap and secure overlapped pieces with wire or screws per standard industry practice.

To affix the 12mm plasterboard/Soundblock board to the IsoMax channels.

For one layer use plasterboard screws suitable for self drilling into a metal stud system at 25mm in length.

When using two layers of plasterboard the first layer should be affixed using a 25mm long screw as above, the second layer should be affixed using 35mm long screw into the channel.

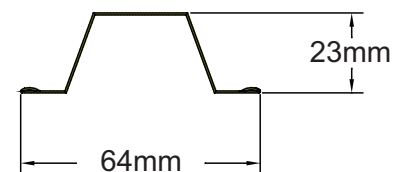

Northern Office:

Unit 4 Eagle Park, Eagle Park Drive,
Warrington. WA2 8JA
t: 01925 577711 f: 01925 577733

Southern Office:

Unit 9 Enterprise Way
Wickford SS11 8DH
t: 01268 568762 f: 01268 568764

info@cmsacoustics.co.uk
www.cmsacoustics.co.uk

CMS ACOUSTIC
SOLUTIONS

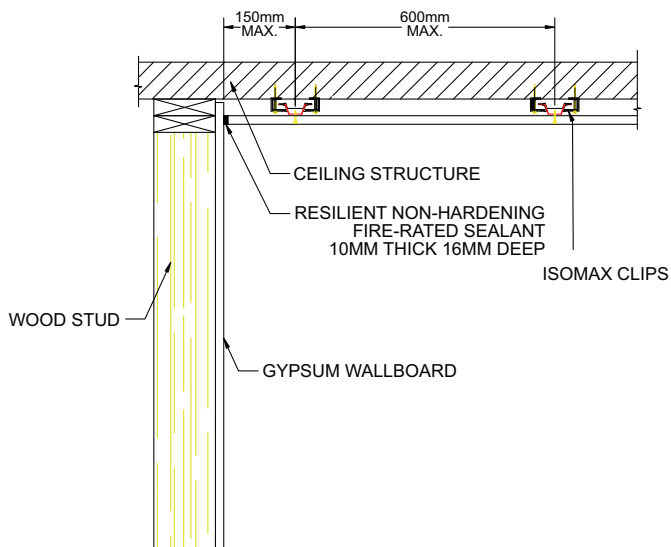

RESILIENTLY MOUNTED CEILING WITH DIRECT ATTACHED WALL

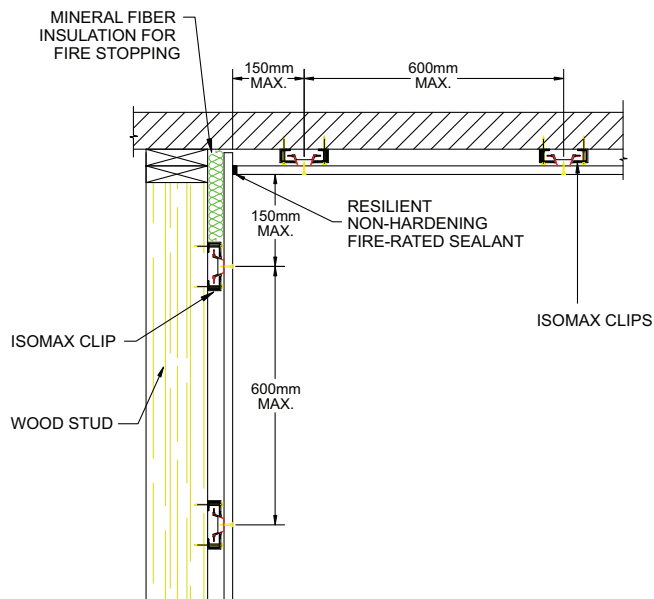

RESILIENTLY MOUNTED WALL & CEILING

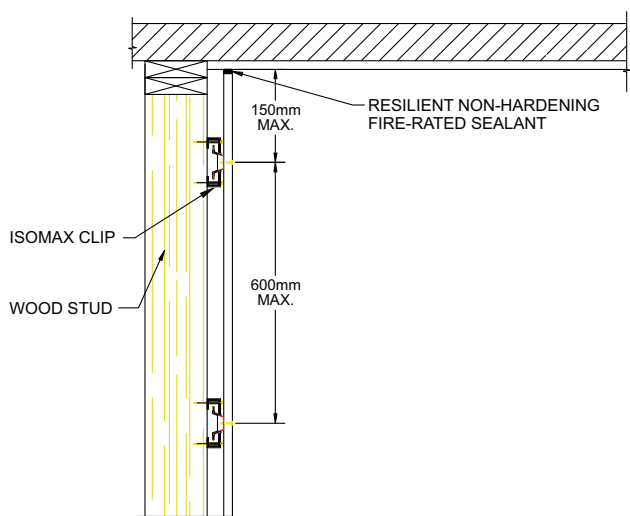

RESILIENTLY MOUNTED WALL WITH DIRECT ATTACHED CEILING

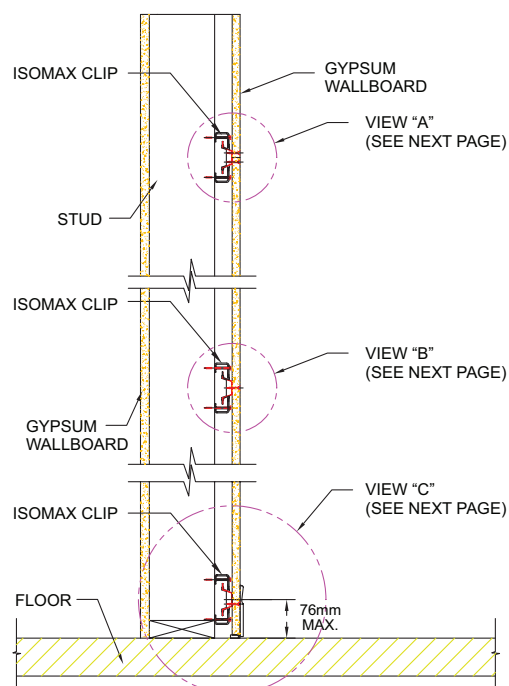

WALL/FLOOR SECTION

NOTE: FOR ACOUSTICAL ISOLATION BASE BOARD OR ANY OTHER WALL ATTACHMENTS MUST NOT TOUCH THE FLOOR.

Northern Office:

Unit 4 Eagle Park, Eagle Park Drive,
Warrington. WA2 8JA
t: 01925 577711 f: 01925 577733

Southern Office:

Unit 9 Enterprise Way
Wickford SS11 8DH
t: 01268 568762 f: 01268 568764

info@cmsacoustics.co.uk
www.cmsacoustics.co.uk



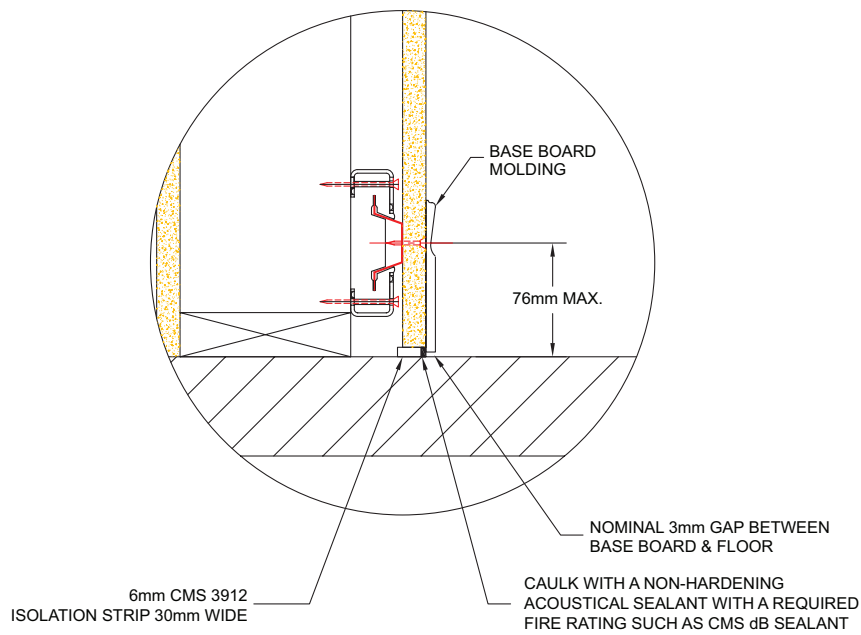

ENLARGED VIEW "C"

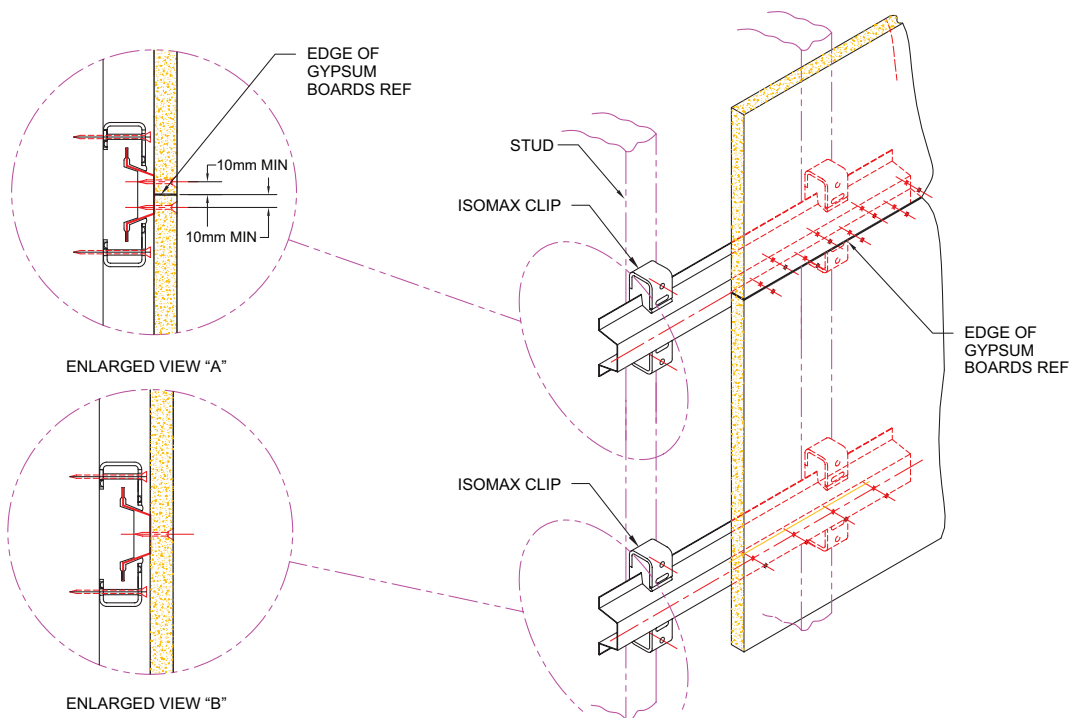

Northern Office:

Unit 4 Eagle Park, Eagle Park Drive,
Warrington. WA2 8JA
t: 01925 577711 f: 01925 577733

Southern Office:

Unit 9 Enterprise Way
Wickford SS11 8DH
t: 01268 568762 f: 01268 568764

info@cmsacoustics.co.uk
www.cmsacoustics.co.uk



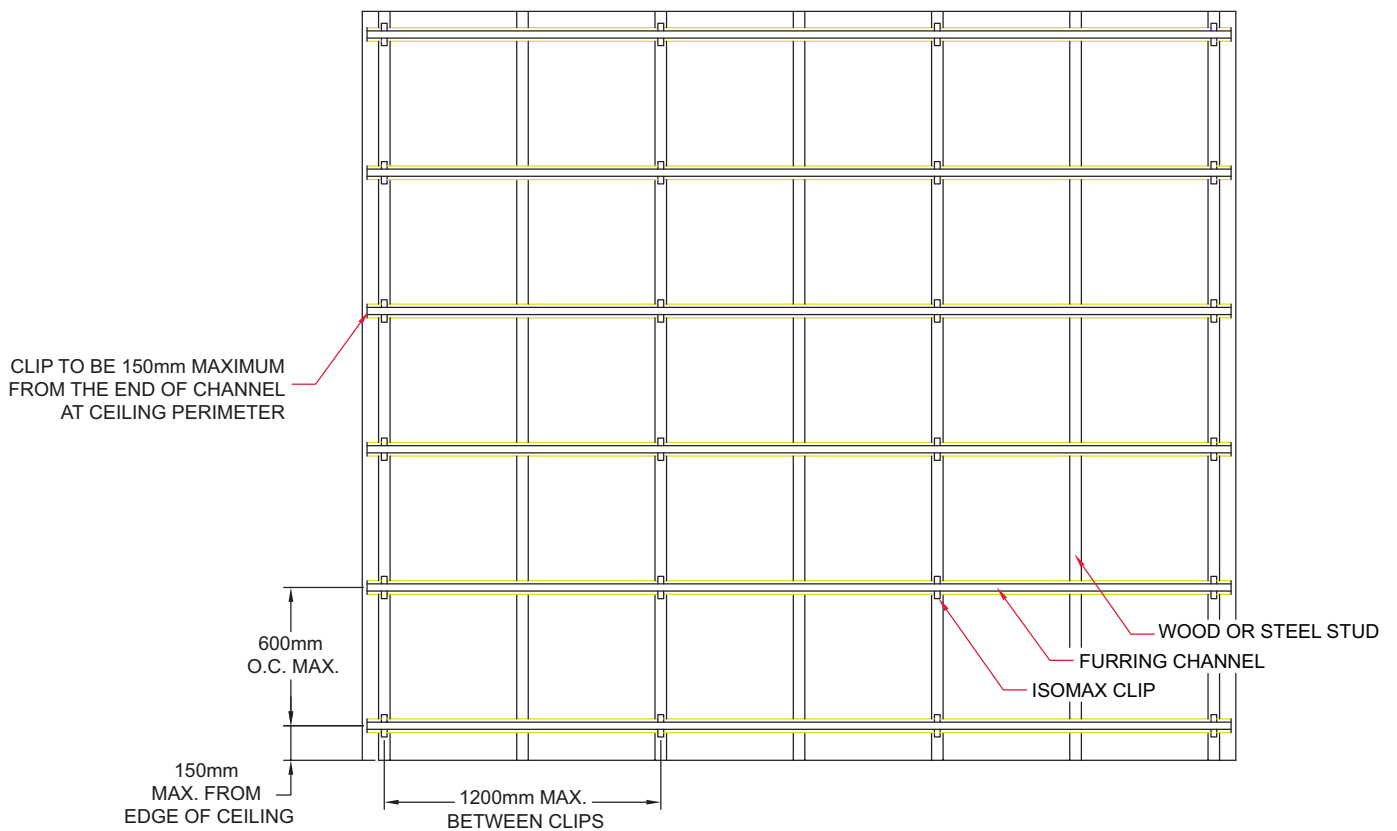
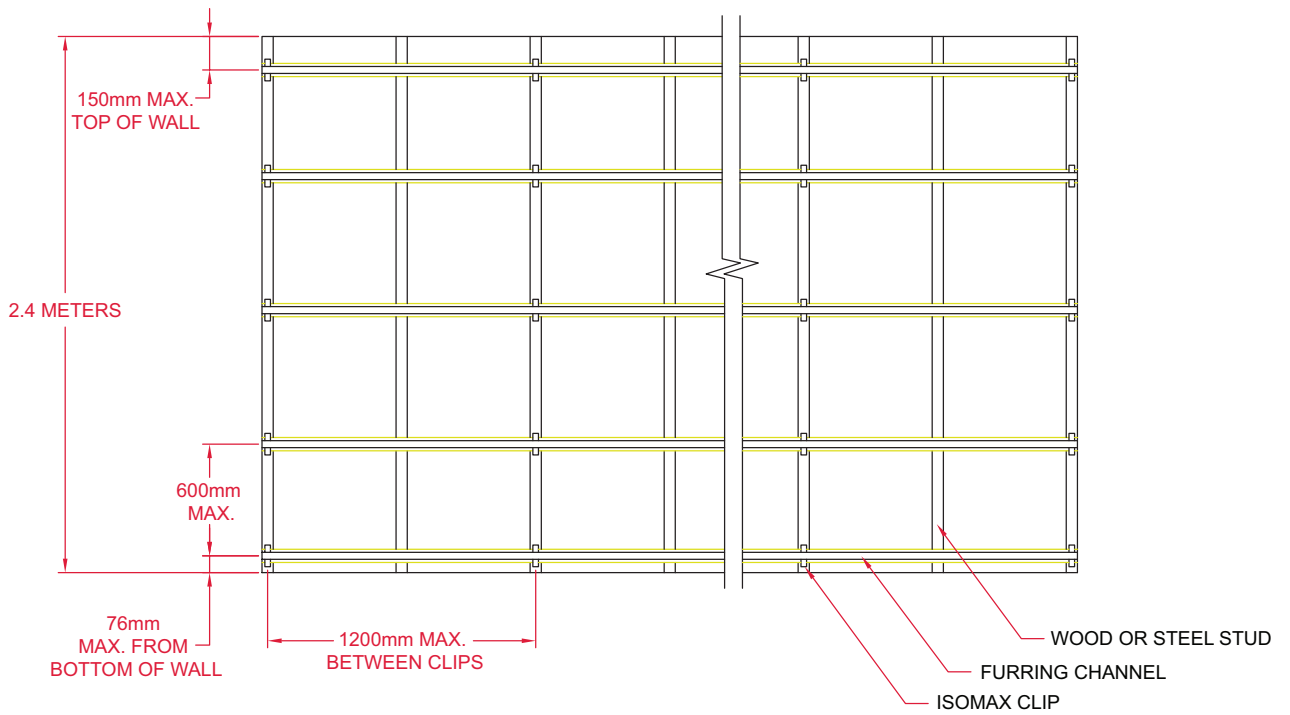

Northern Office:

Unit 4 Eagle Park, Eagle Park Drive,
Warrington. WA2 8JA
t: 01925 577711 f: 01925 577733

Southern Office:

Unit 9 Enterprise Way
Wickford SS11 8DH
t: 01268 568762 f: 01268 568764

info@cmsacoustics.co.uk
www.cmsacoustics.co.uk

